	NAME:							
	Gr 7		Date:		Time	45 mins		
CAPS Reference	2-2 Functions and relationships							
Topic	2-2-2 Calculating the rule							

### 1. Got it? [ 15 mins]



**Finding the relationship rule when given the input and the output values.**

#### Example 1:

Here is a table with input and output values. What is the rule?

x (Input)	1	2	3	4	5	6	7	8
y (Output)	4	8	12	16	20	24	28	32

**Use the table to investigate the relationship between x (Input) and y (Output)**

$x = 1; y = 4$  How do I get from 1 to 4? I can say  $1 + 3$  or  $1 \times 4$

$x = 2; y = 8$  How do I get from 2 to 8? I can say  $2 + 6$  or  $2 \times 4$

The common method is  $x \times 4$ .

Test this with  $x = 3; y (3 \times 4) = 12$  and  $x = 4; y (4 \times 4) = 16$

We can conclude that the rule is  $y = 4 \times x$  or  $4x$

#### Example 2:

Here is a table with input and output values. What is the rule?

x (Input)	1	2	3	4	5	6	7	8
y (Output)	3	4	5	6	7	8	9	10

**Use the table to investigate the relationship between x (Input) and y (Output)**

$x = 1; y = 3$  How do I get from 1 to 3? I can say  $1 + 2$  or  $1 \times 3$

$x = 2; y = 4$  How do I get from 2 to 4? I can say  $2 + 2$  or  $2 \times 2$

The common method is  $x + 2$

Test this with  $x = 3; y (3 + 2) = 5$  and  $x = 4; y (4 + 2) = 6$

We can conclude that the rule is  $y = x + 2$ .

#### Example 3:

Here is a table with input and output values. What is the rule?

x (Input)	0	1	2	3	4	5	6	7
y (Output)	2	5	8	11	14	17	20	23

**Use the table to investigate the relationship between x (Input) and y (Output)**

$x = 0; y = 2$  How do I get from 0 to 2? I can say  $0 + 2$  or any number  $\times 0 + 2$

$x = 1; y = 5$  How do I get from 1 to 5? Add 2 is part of the rule (see  $0 \times x + 2 = 2$ )

$1 \times x + 2 = 5$   $x = 3$   $2 \times x + 2 = 8$  Again,  $x = 3$

Test  $x = 3$  with the other input and output numbers. It "works".

We conclude that the rule is:  $y = 3x + 2$



## 2. Go ahead! [ 20 mins]

2.1 Find the rule for the input and output values in these tables:

2.1.1

Input number (x)	1	2	3	4	5	6
Output number (y)	4	8	12	16	20	24

2.1.2

Input number (x)	0	1	2	3	4	5
Output number (y)	3	4	5	6	7	8

2.1.3

Input number (x)	0	2	4	6	8	10
Output number (y)	5	6	7	8	9	10

2.2 Find the rule for the input and output values in these flow diagram:

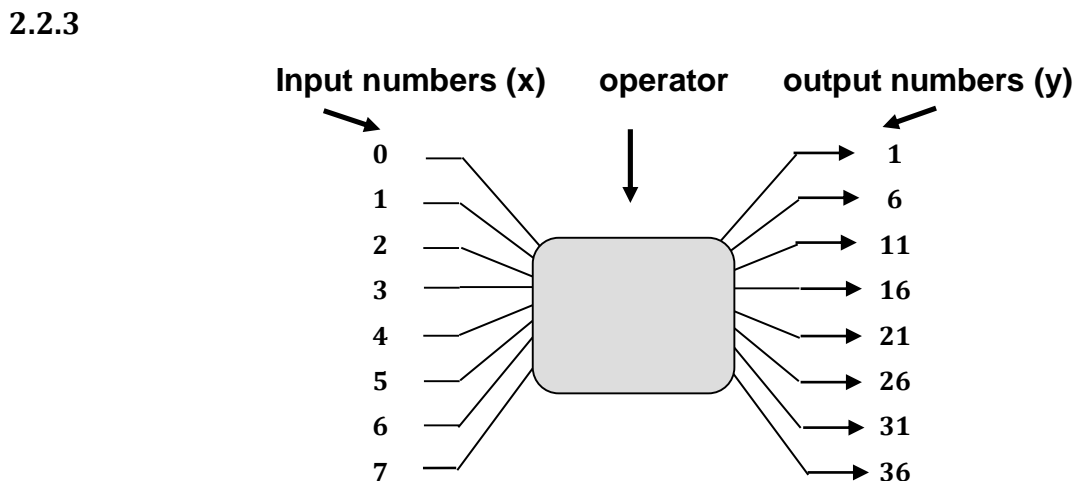
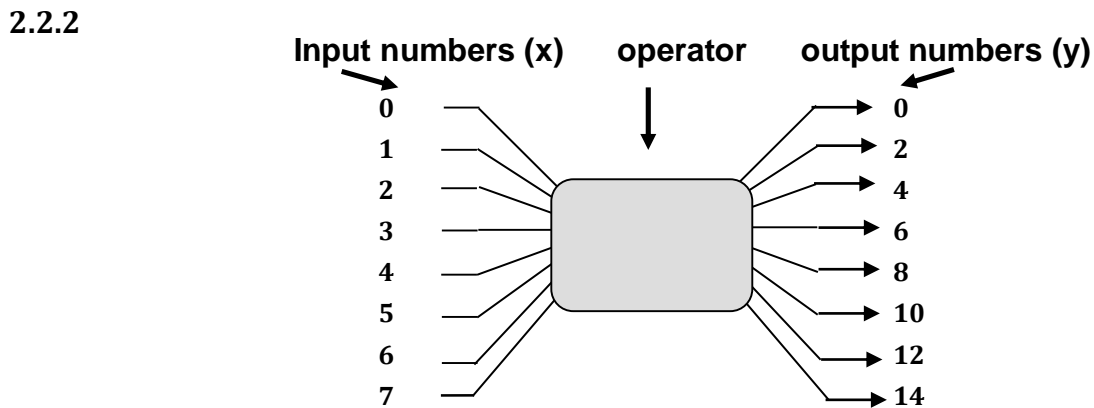
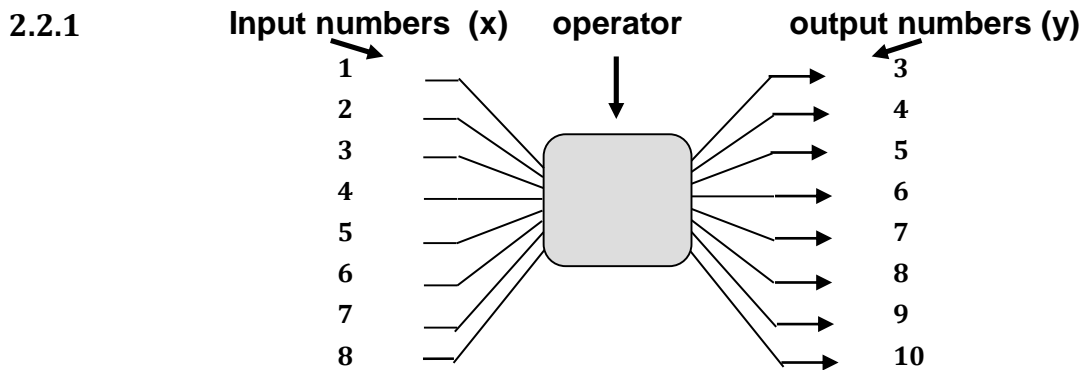

## 3. Check your work! [ 10 mins]